

## Different Types of UPS Systems

The table below summarizes the various types of UPS designs and their characteristics:

Types of UPS	Practical Power Range (kVA)	Voltage Conditioning	Cost per VA	Efficiency	Inverter always operating
Standby	0 - 0.5	Low	Low	Very High	No
Line Interactive	0.5 - 5	Design Dependent	Medium	Very High	Design Dependent
Standby Ferro	3 - 15	High	High	Low - Medium	No
Double Conversion On-Line	5 - 5000	High	Medium	Low - Medium	Yes
Delta Conversion On-Line	5 - 5000	High	Medium	High	Yes

These types of UPS systems will be explained in the following paragraphs.

To understand UPS types you should first have a high-level design overview of an Uninterruptible Power Supply (UPS) system. Each UPS consists of these basic components:

1. Rectifier/ Charger – converts AC current to DC
2. Inverter – converts DC to AC current
3. Batteries – provides backup power for the inverter

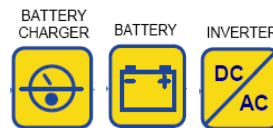

**Standby** is the most commonly used type of UPS system for less critical applications between 0.5 and 5kVA. In the block diagram below (Figure #1), the transfer switch is set to choose the primary AC power source (solid line path), and switches to the battery/ inverter as the backup source should the primary source fail. When that happens, the transfer switch must operate to switch the load over to the battery/ inverter backup power source (dashed line path). The inverter only starts when the power fails, hence the name "Standby".

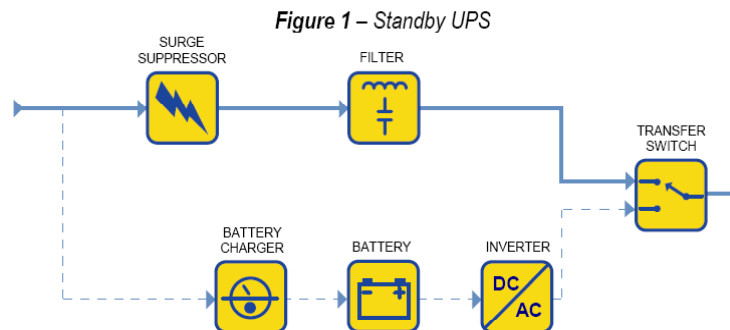

**Line Interactive**, illustrated in Figure 2, is used most often in more critical applications between 0.5 and 5kVA. In this design, the battery-to-AC power converter (inverter) is always connected to the output of the UPS. Operating the inverter in reverse during times when the input AC power is normal provides battery charging.

When the input power fails, the transfer switch opens and the power flows from the battery to the UPS output. With the inverter always on and connected to the output, this design provides additional filtering and yields reduced switching transients and longer battery life when compared with the Standby UPS topology.

Figure 2 – Line Interactive UPS

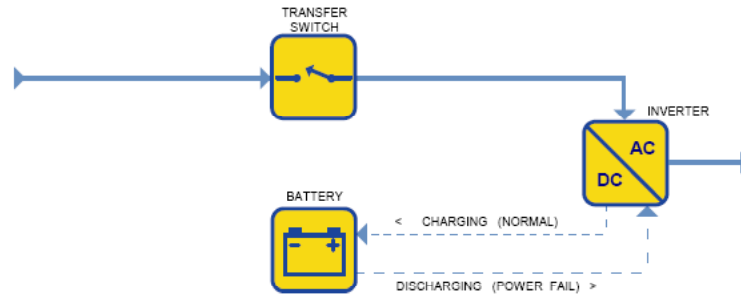

Standby-Ferro UPS design in Figure #3 depends on a special saturating transformer that has three windings (power connections). The primary power path is from AC input, through a transfer switch, through the transformer, and to the output. In the case of a power failure, the transfer switch is opened, and the inverter picks up the output load.

In the Standby-Ferro design, the inverter is in the standby mode, and is energized when the input power fails and the transfer switch is opened.

Standby-Ferro UPS systems are frequently represented as On-Line units, even though they have a transfer switch, the inverter operates in the standby mode, and they exhibit a transfer characteristic during an AC power failure. Figure 3 illustrates this Standby-Ferro topology.

Figure 3 – Standby-Ferro UPS

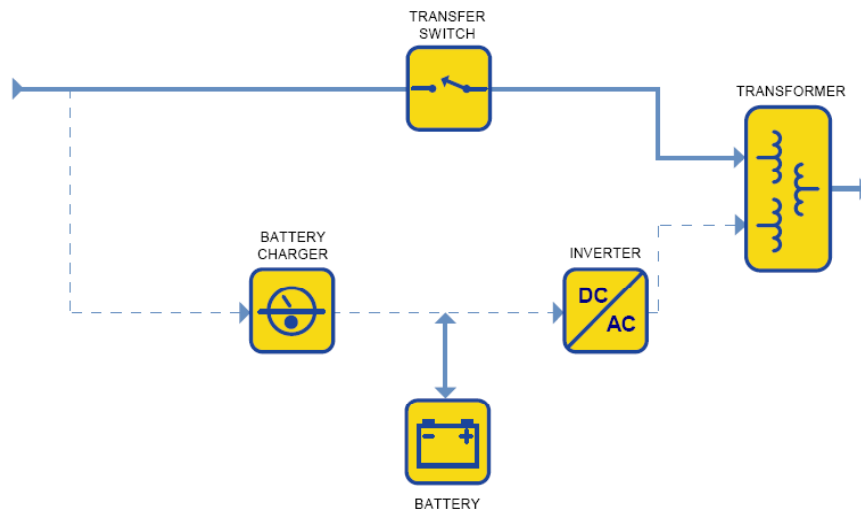

Double Conversion On-Line is a very common type of UPS above 10kVA. The block diagram of the Double Conversion On-Line UPS, illustrated in Figure 4, is the same as the Standby, except that the primary power source is the inverter instead of the AC main.

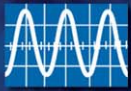
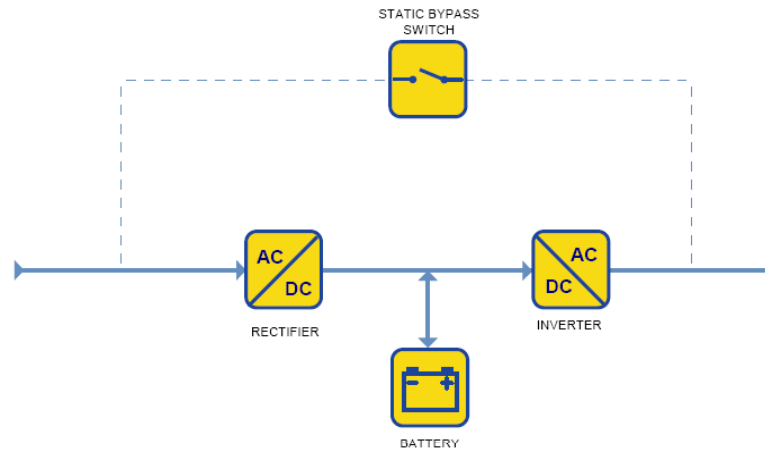

Figure 4 – Double Conversion On-Line UPS



In the Double Conversion On-Line design, failure of the input AC does not cause activation of the transfer switch, because the inverter is already on-line as a normal state and simply begins drawing power from the battery instead of the rectifier. Therefore, during an input AC power failure, on-line operation results in no transfer time. Both the battery charger and the inverter convert the entire load power flow in this design, resulting in reduced efficiency with its associated increased heat generation in many older designs.

This UPS provides nearly ideal electrical output performance. But the constant wear on the power components reduces reliability over other designs and the energy consumed by the electrical power inefficiency is a significant part of the life-cycle cost of the UPS. Also, the input power drawn by the large battery charger is often non-linear and can interfere with building power wiring or cause problems with standby generators.

Delta Conversion On-Line UPS design illustrated in Figure 5 is an advanced technology designed to eliminate the drawbacks of many existing double conversion designs and is available in sizes ranging from 5kVA to 1.6MW. Similar to the Double Conversion On-Line design, the Delta Conversion On-Line UPS always has the inverter supplying the load voltage.

Figure 5 – Delta Conversion On-Line UPS

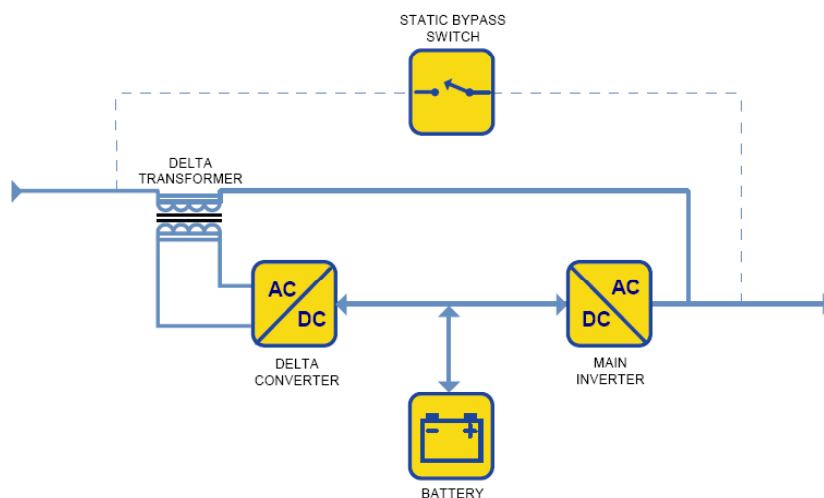

However, the Delta Conversion design does not require two conversions of the total power flow (AC in to DC, then DC back to AC out), and thus operates at greater efficiency than double conversion systems. And the input and output performance is actually improved over double conversion designs. This is particularly applicable in power requirements above 80 kW.

Some manufactures of UPS equipment continue to "mis-state" the actual facts of this superior design. For a full technical review of the Delta Conversion technology or any of these technologies, call us for an in-house seminar. We are always glad to set the facts right!